

Mõõdud

üldpikkus [mm]	2300 (2150)
üldlaius [mm]	2190 (2000)
kõrgus [mm]	2560 (1930)

Kaalud

Korpus [kg]	800
Seadmed [kg]	1000
kogumass (ilma trafota) [kg]	ca. 1800

Värvid:

katus	RAL6015
korpus	RAL7035

Märkus:

Alajaama transport ja montaaž teha vastavalt seadmetega kaasas olevale transpordi- ja vundamendijuhendile

Töötas välja peeter.puusepp 11.05.2020		Kontrollis	Kinnitas	Tellija projekti Nr.	Projekti Nimi ELV2019	Projekti ERP number XXXX	Paigaldis = HEJA2VMF B (5KP)	Asukoht+			
Muudatus	Kuupäev	Märkus		Tellija dokumendi Nr.			Dokumendi Nr. XXXX_ETC	Muudatus		Dokumendi tüüp ETC	
				Tellija Elektrilevi OÜ	Kirjeldus JP tüüp 2 VM 3..5KP, KPMK-ga ,OT B	 Harju Elekter Elektrotehnika AS +372 674 7449 info.heet@harjuelekter.com	Paldiski mnt. 31 76606 Keila Estonia	Formaat DIN A3	Mõõtkava 1 : 24	Leht 2	Lehti 1

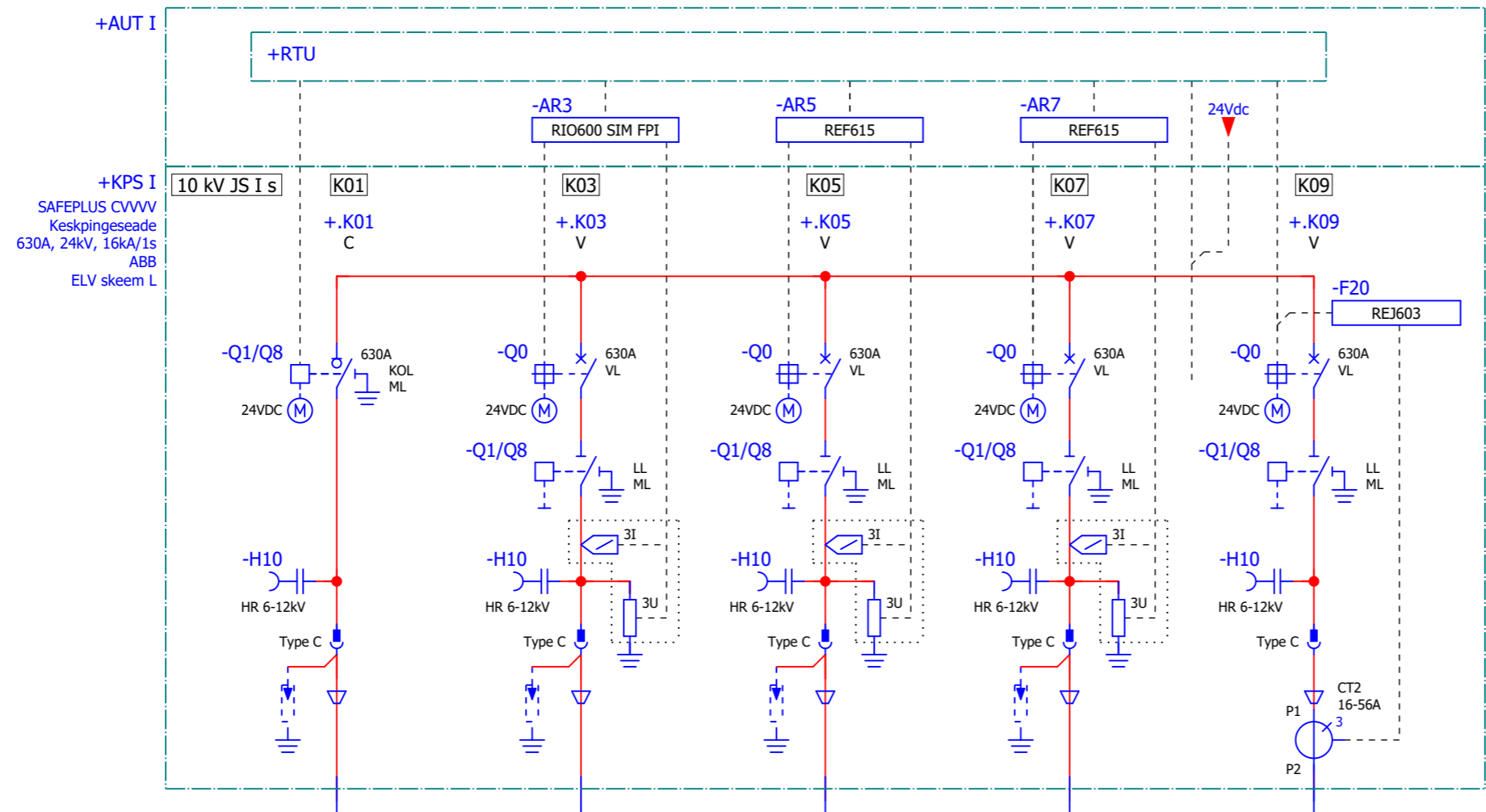

-W2
HXCMK 12/20kV
3x35
12/20kV

-W1
HXCMK 12/20kV
2x35
12/20kV

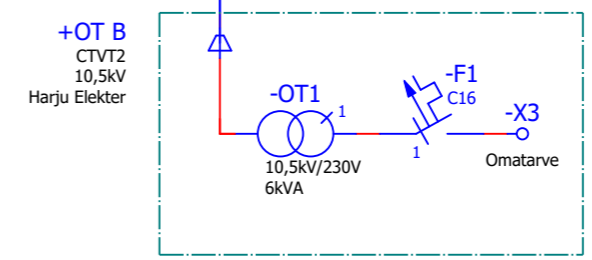
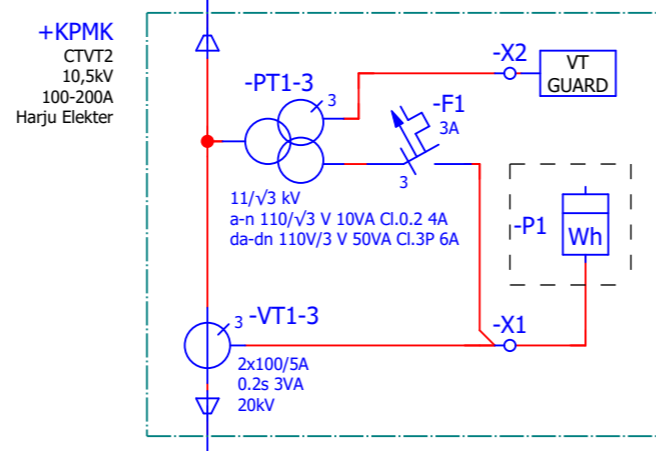

Töötas välja peeter.puusepp 11.05.2020		Kontrollis	Kinnitas	Tellija projekti Nr.	Projekti Nimi ELV2019	Projekti ERP number XXXX	Paigaldis = HEJA2VMF B (5KP)	Asukoht+		
Muudatus	Kuupäev	Märkus		Tellija dokumendi Nr.			Dokumendi Nr. XXXX_EFS1	Muudatus		Dokumendi tüüp EFS1
				Tellija Elektrilevi OÜ	Kirjeldus Peaskeem KPS, KPMK, OT B	 Harju Elekter Elektrotehnika AS +372 674 7449 info.heet@harjuelekter.com	Paldiski mnt. 31 76606 Keila Estonia	Möötkava	Leht	Lehti
							DIN A3	1 : 1	3	1

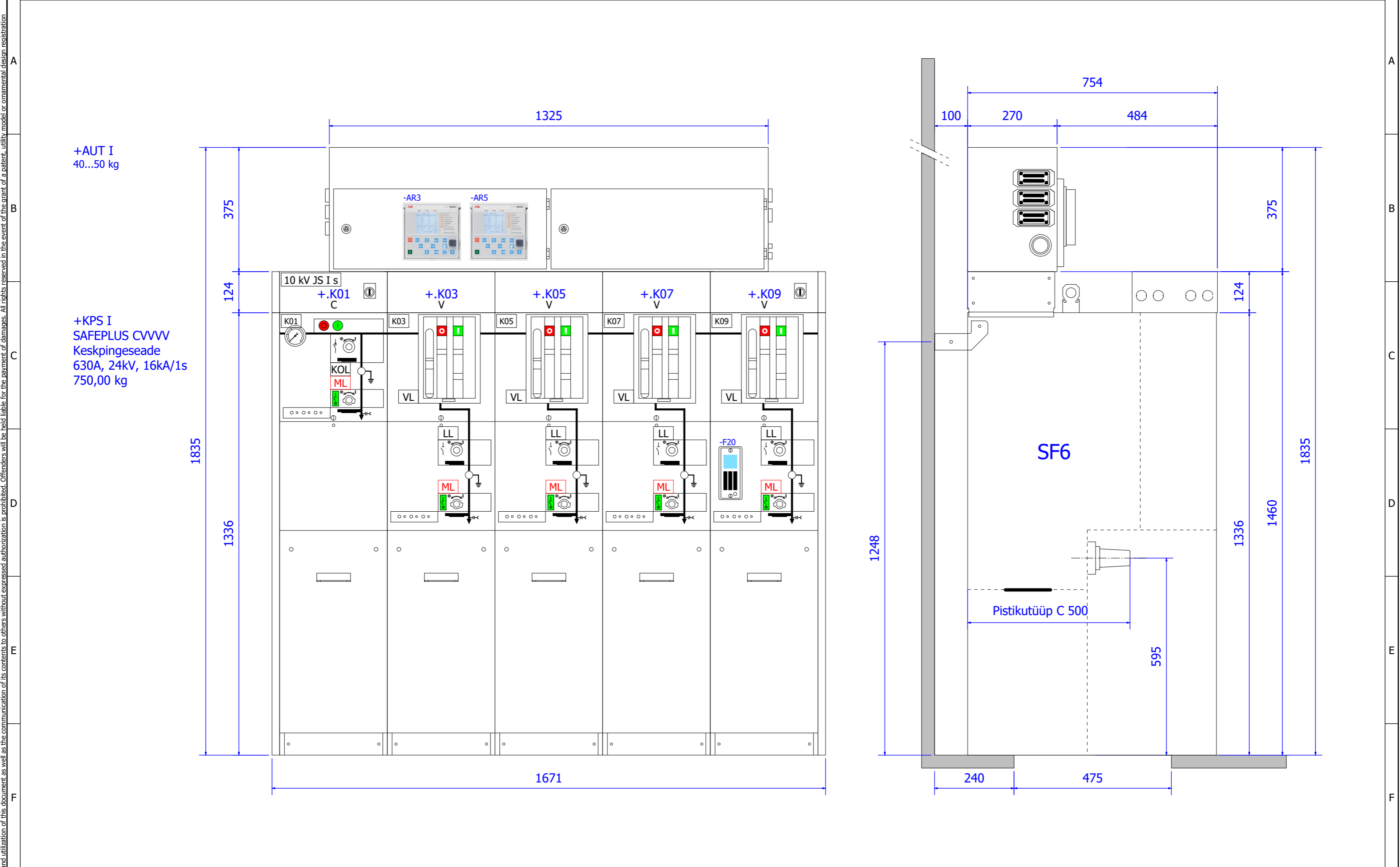

+AUT I
40...50 kg

+KPS I
SAFEPLUS CWWW
Keskpingseseade
630A, 24kV, 16kA/1s
750,00 kg

1835

1336

375

124

1325

1671

754

100

270

484

375

124

1248

SF6

1336

1460

1835

Pistikutüüp C 500

595

240

475

Töötas välja peeter.puusepp 11.05.2020		Kontrollis	Kinnitas	Tellija projekti Nr.	Projekti Nimi ELV2019	Projekti ERP number XXXX	Paigaldis = HEJA2VMF B (5KP)	Asukoht+ KPS		
Muudatus	Kuupäev	Märkus		Tellija dokumendi Nr.			Dokumendi Nr. XXXX_ETC	Muudatus	Dokumendi tüüp ETC	
				Tellija Elektrilevi OÜ	Kirjeldus L skeem ABB SafePlus CWWW	Harju Elekter Elektrotehnika AS +372 674 7449 info.heet@harjuelekter.com	Paldiski mnt. 31 76606 Keila Estonia	Möötkava 1 : 10	Leht 4	Lehti 1

Kaal ca 300kg

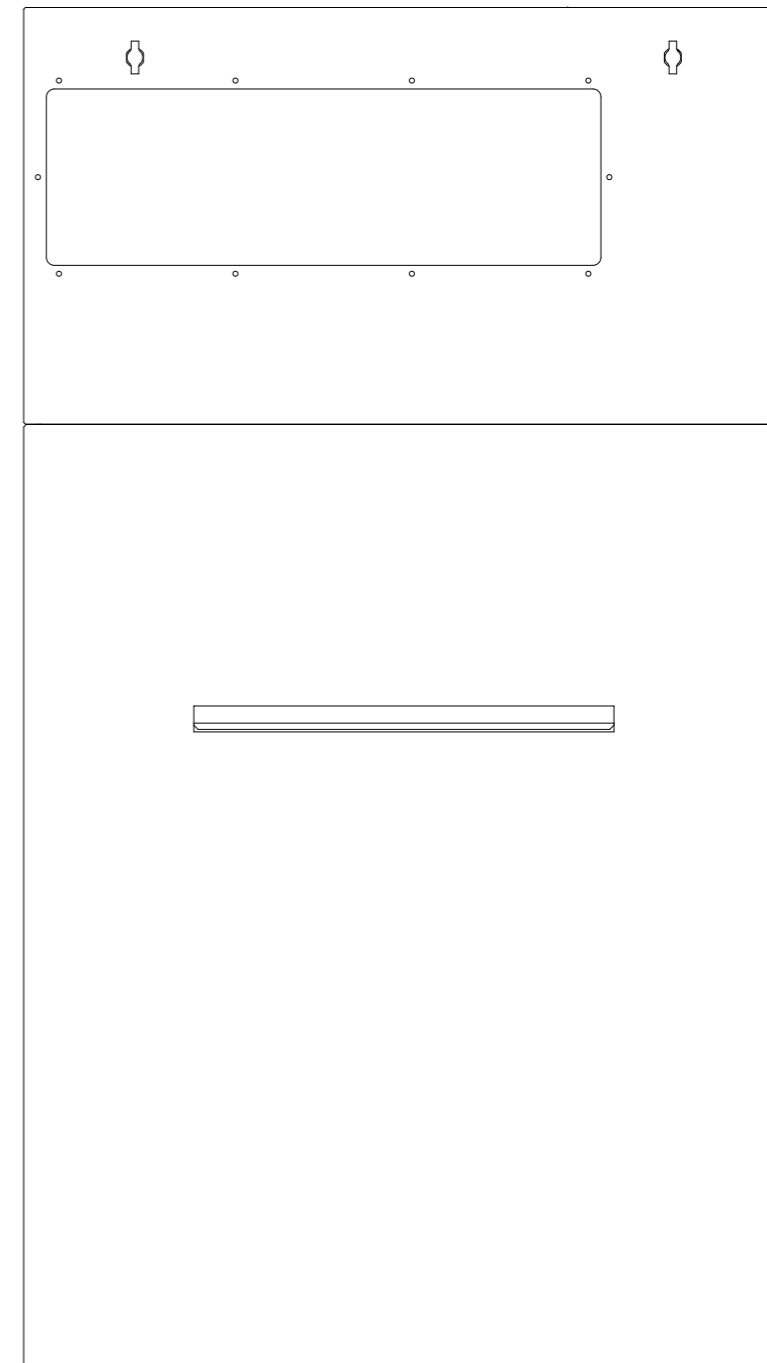
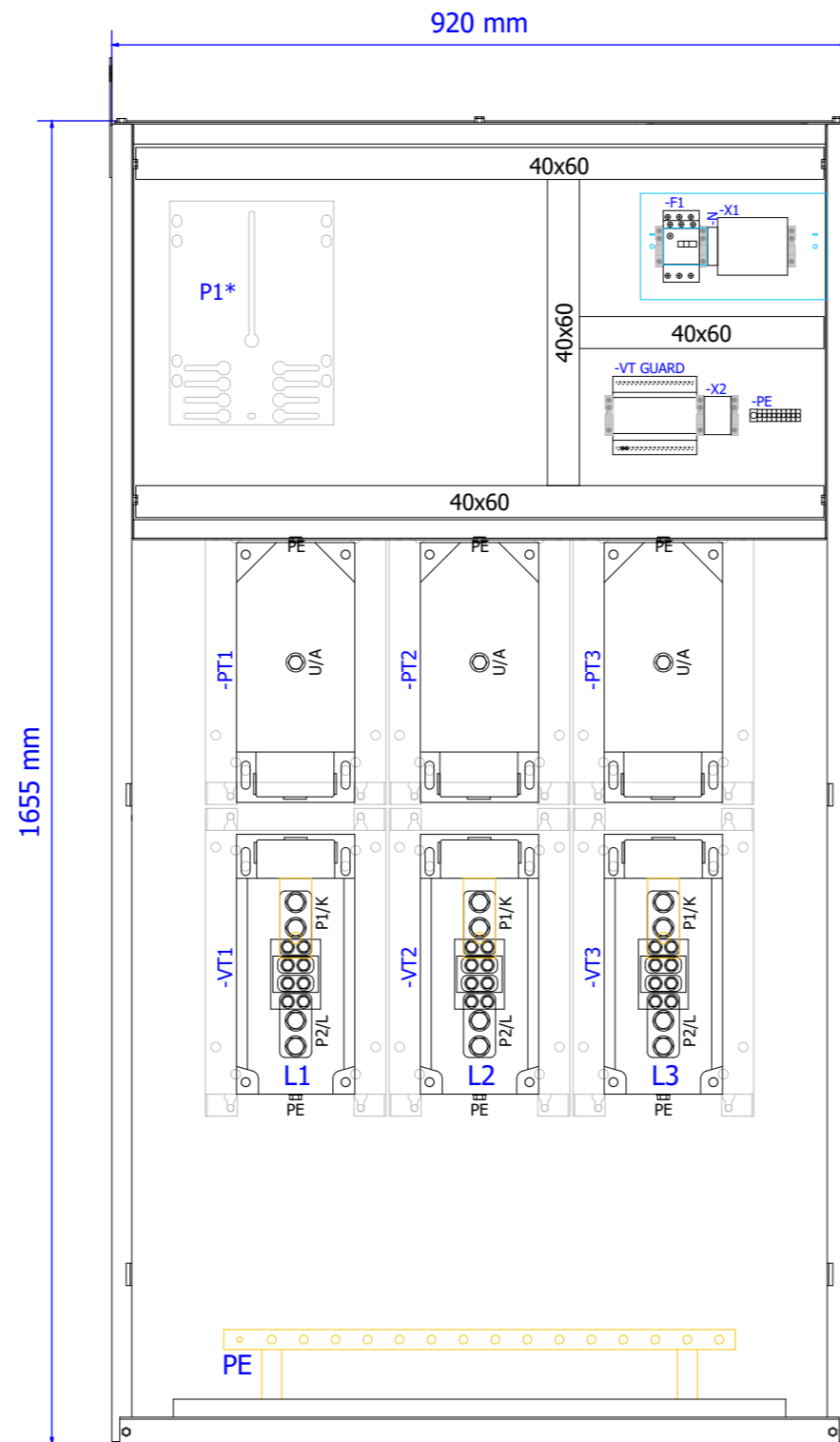
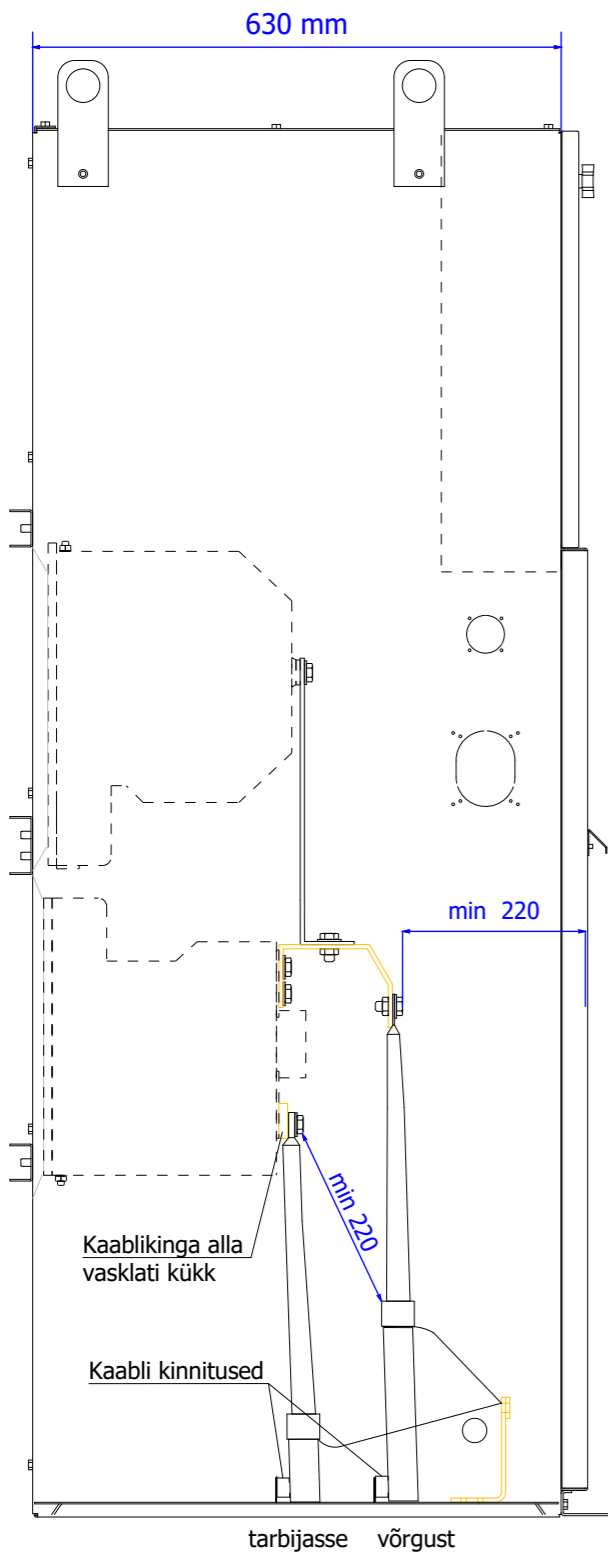

Töötas välja peeter.puusepp 11.05.2020		Kontrollis	Kinnitas	Tellija projekti Nr.	Projekti Nimi ELV2019	Projekti ERP number XXXX	Paigaldis = HEJA2VMF B (5KP)	Asukoht+ KPMK		
Muudatus	Kuupäev	Märkus		Tellija dokumendi Nr.			Dokumendi Nr. XXXX_ETC	Muudatus		
				Tellija Elektrilevi OÜ	Kirjeldus KPMK Paigutusjoonis	 Harju Elekter Elektrotehnika AS +372 674 7449 info.heet@harjuelekter.com	Paldiski mnt. 31 76606 Keila Estonia	Möötkava 1 : 9	Leht 5	Lehti 1

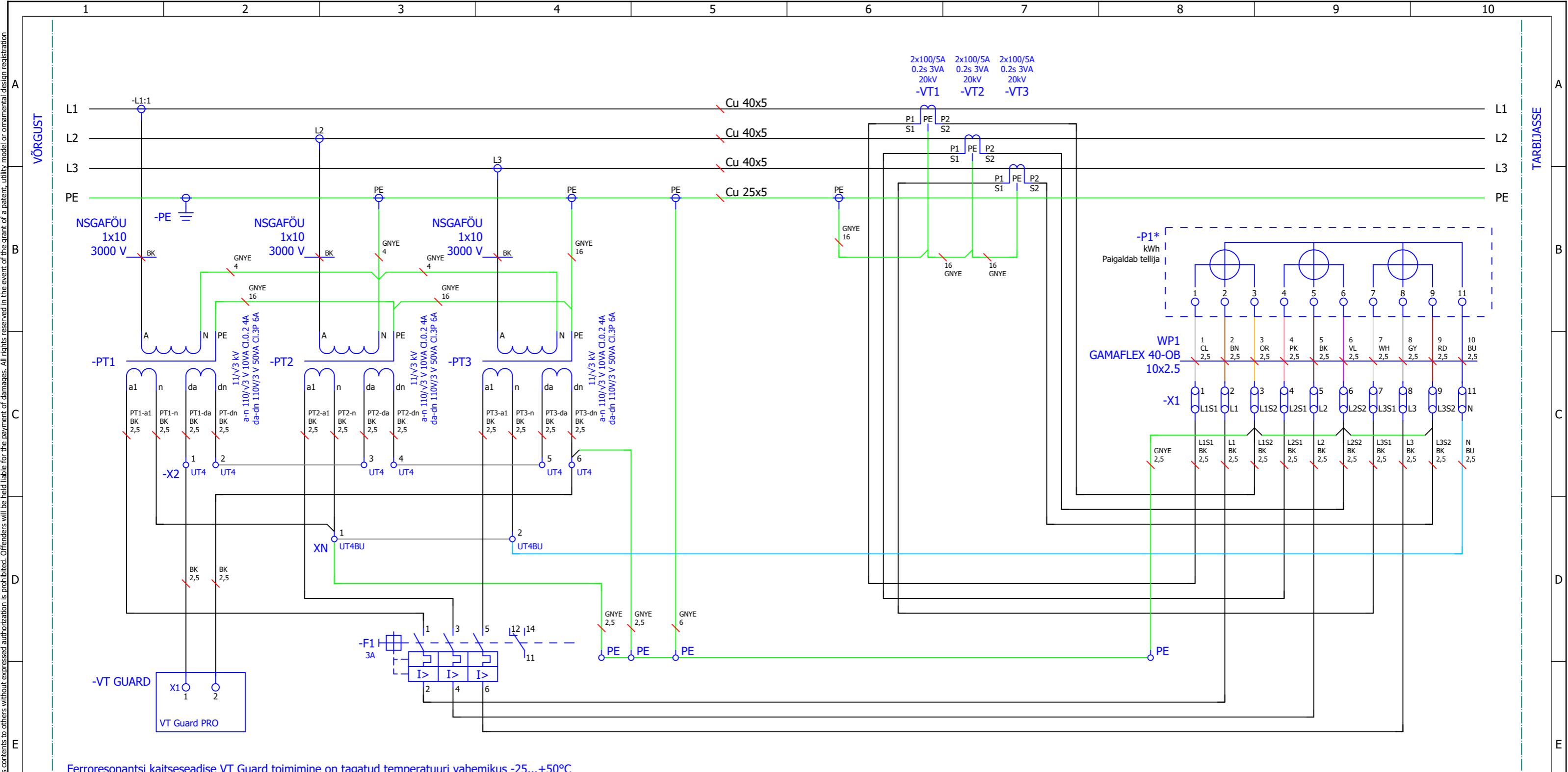

Ferroresonantsi kaitseseadise VT Guard toimimine on tagatud temperatuuri vahemikus -25...+50°C

Töötas välja peeter.puusepp 11.05.2020	Kontrollis	Kinnitas	Tellija projekti Nr.	Projekti Nimi ELV2019	Projekti ERP number XXXX	Paigaldis = HEJA2VMF B (5KP)	Asukoht+ KPMK	
Muudatus	Kuupäev	Märkus	Tellija dokumendi Nr.	Kirjeldus KPMK Juhtimis skeem	HARJU ELEKTER® Harju Elekter Elektrotehnika AS +372 674 7449 info.heet@harjuelekter.com	Dokumendi Nr. XXXX_EFS2	Muudatus	Dokumendi tüüp EFS2
			Tellija Elektrilevi OÜ		Paldiski mnt. 31 76606 Keila Estonia	Formaat DIN A3	Möötkava 1 : 1	Leht 6
							Leht 6	Lehti 1

Kaal ca 300kg

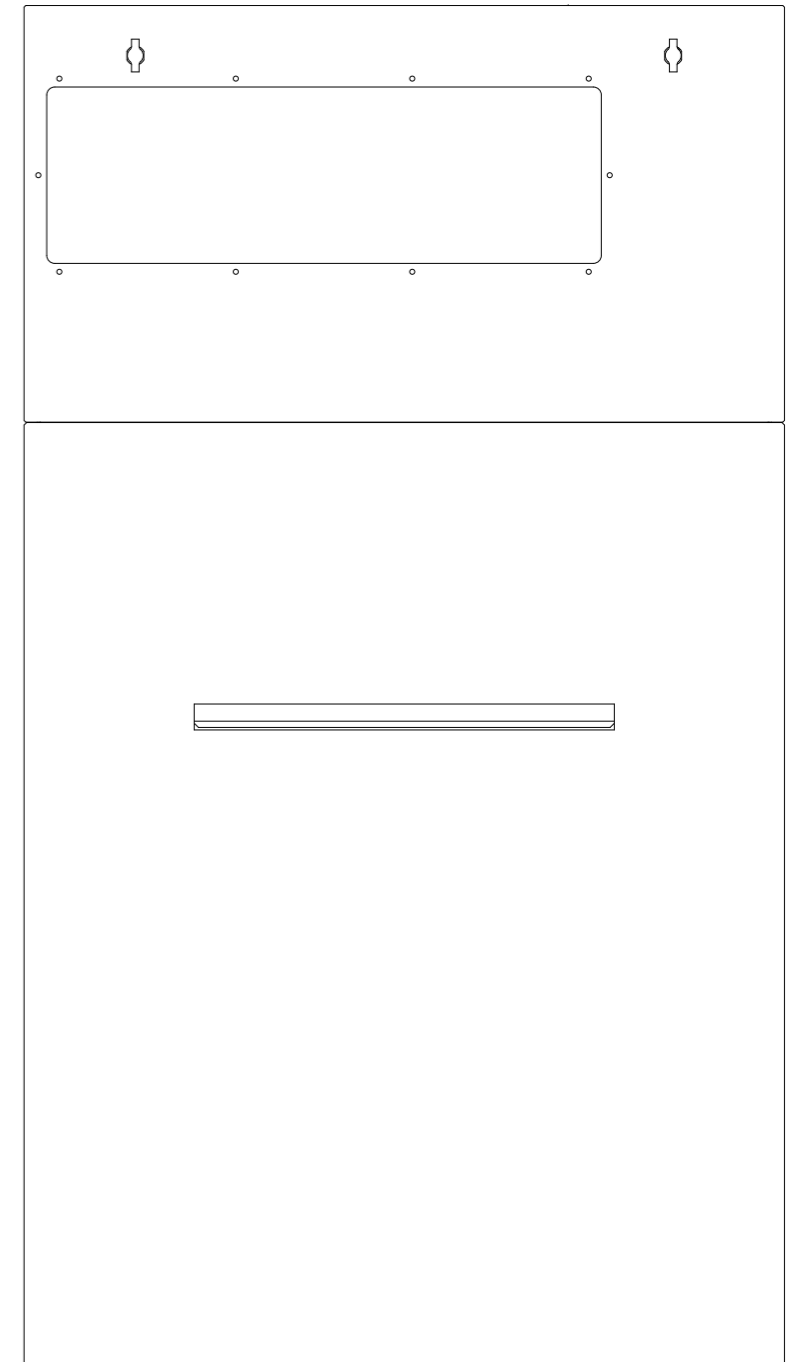
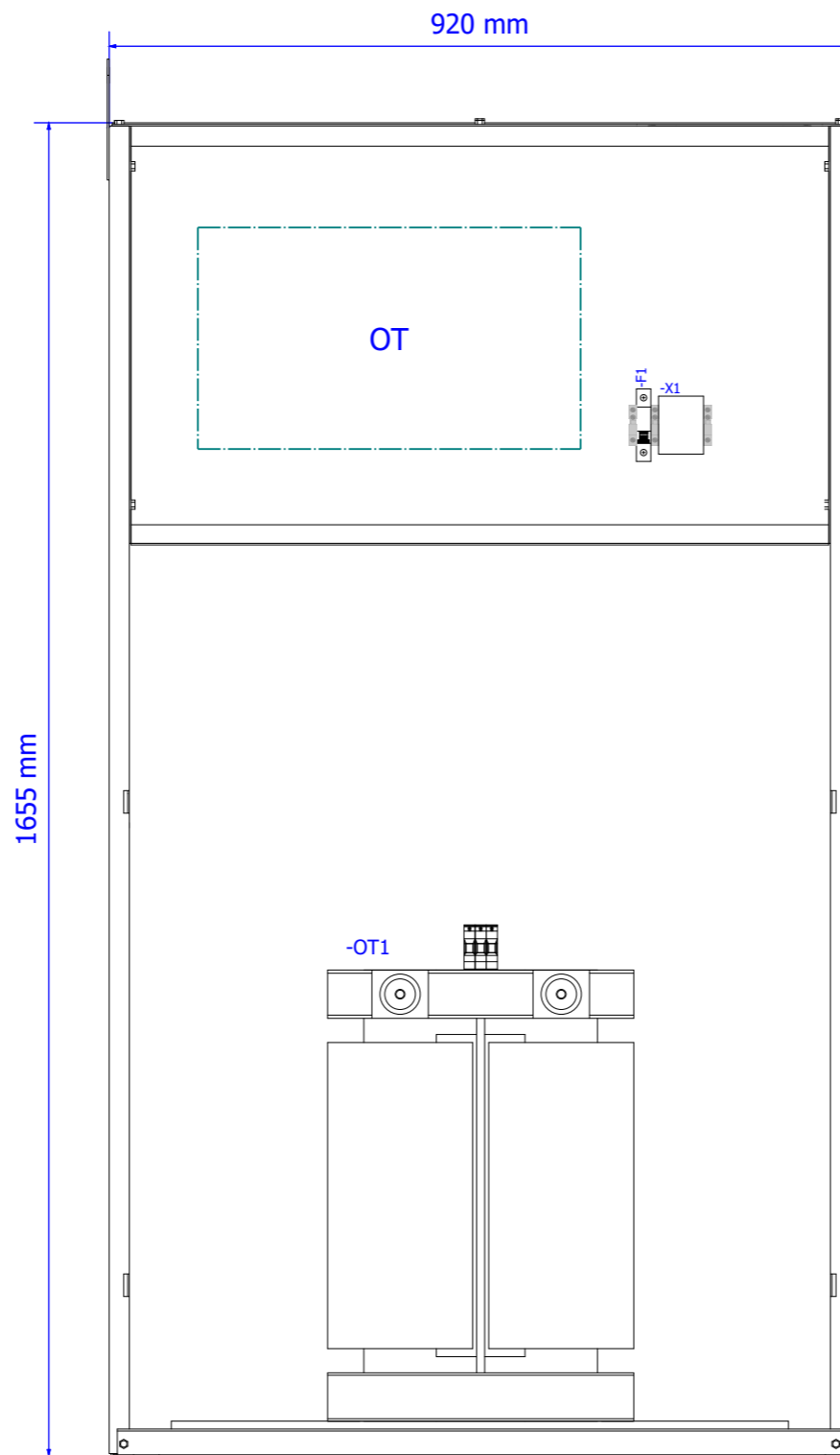
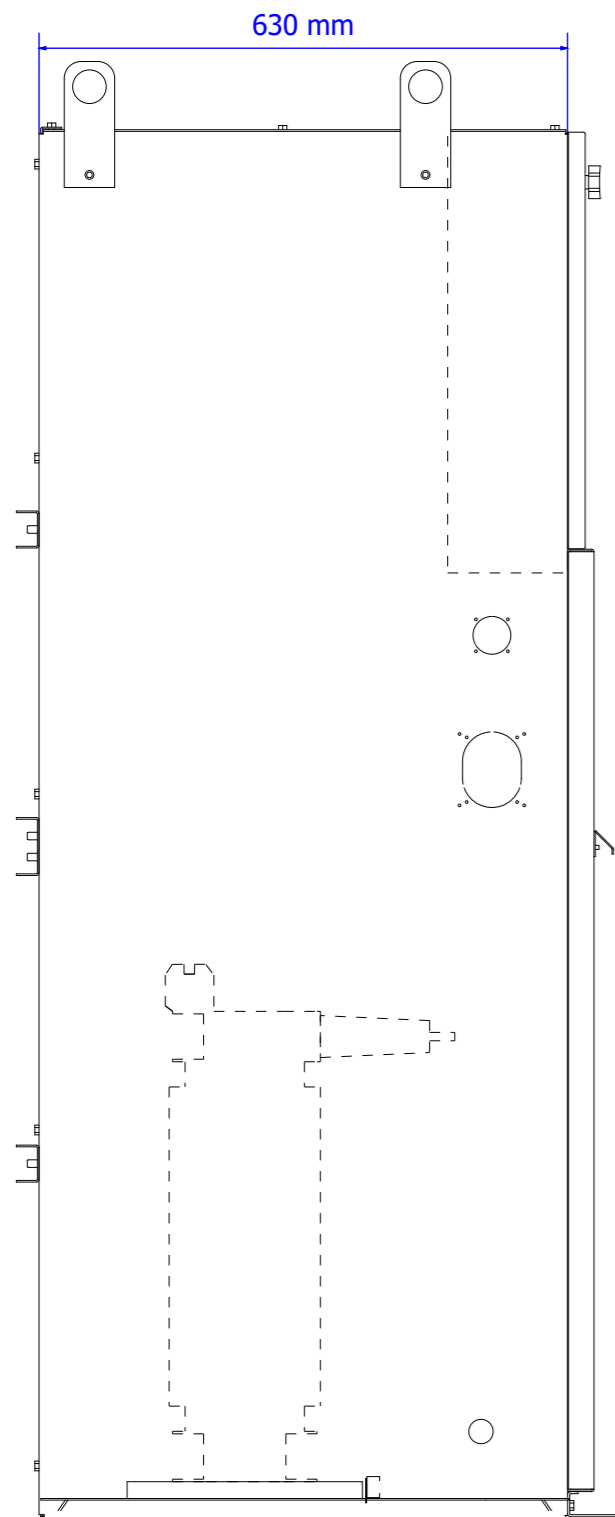

Töötas välja peeter.puusepp 11.05.2020		Kontrollis	Kinnitas	Tellija projekti Nr.	Projekti Nimi ELV2019	Projekti ERP number XXXX	Paigaldis = HEJA2VMF B (5KP)	Asukoht+ OT B		
Muudatus	Kuupäev	Märkus		Tellija dokumendi Nr.			Dokumendi Nr. XXXX_ETC	Muudatus	Dokumendi tüüp ETC	
				Tellija Elektrilevi OÜ	Kirjeldus OT B Paigutusjoonis	 Harju Elekter Elektrotehnika AS +372 674 7449 info.heet@harjuelekter.com	Paldiski mnt. 31 76606 Keila Estonia	Möötkava 1 : 9	Leht 7	Lehti 1

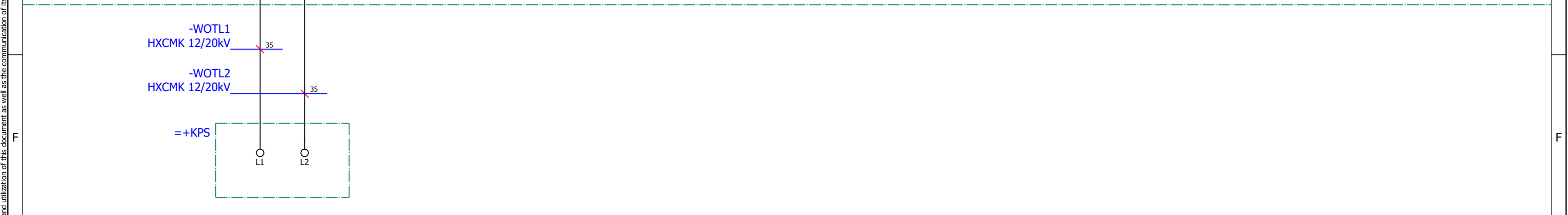
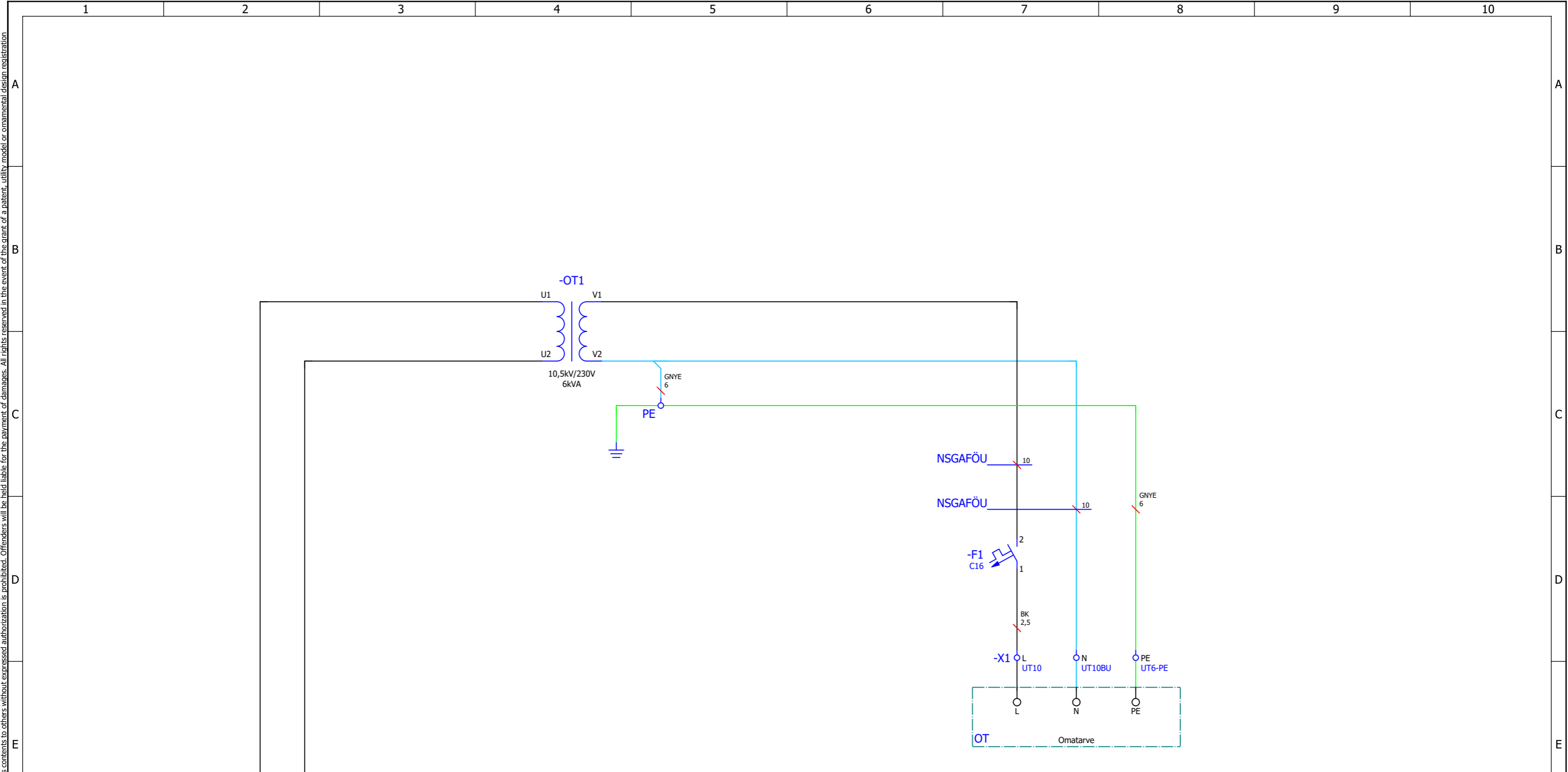

Töötas välja peeter.puusepp 11.05.2020		Kontrollis	Kinnitas	Tellija projekti Nr.	Projekti Nimi ELV2019	Projekti ERP number XXXX	Paigaldis = HEJA2VMF B (5KP)	Asukoht+ OT B		
Muudatus	Kuupäev	Märkus		Tellija dokumendi Nr.			Dokumendi Nr. XXXX_EFS2	Muudatus	Dokumendi tüüp EFS2	
				Tellija Elektrilevi OÜ	Kirjeldus OT B Juhtimisskeem	 Harju Elekter Elektrotehnika AS +372 674 7449 info.heet@harjuelekter.com	Paldiski mnt. 31 76606 Keila Estonia	Mõõtkava 1 : 1	Leht 8	Lehti 1

The copying, distribution and utilization of this document as well as the communication of its contents to others without expressed authorization is prohibited. Offenders will be held liable for the payment of damages. All rights reserved in the event of the grant of a patent, utility model or ornamental design registration.